

USER'S OPERATION MANUAL

Air handling unit with heat (energy) utilization

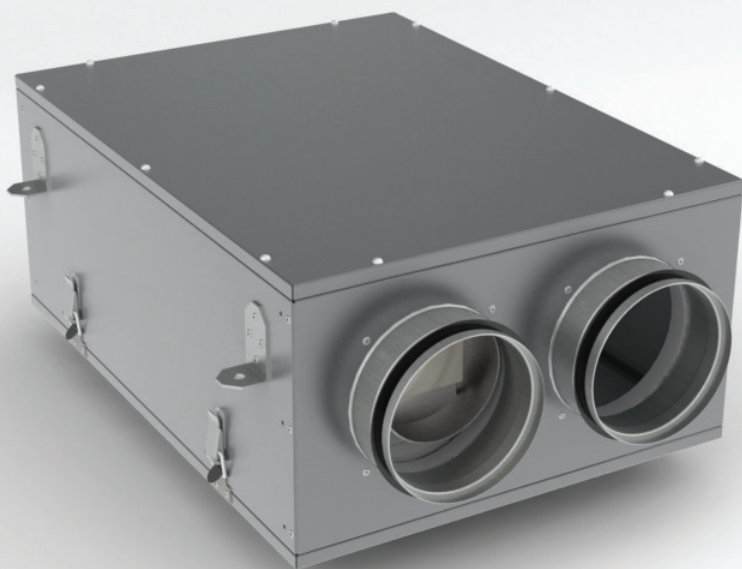

VENTS VUT 100 P mini
VENTS VUE 100 P mini



CONTENT

Introduction.....	3
Application.....	3
Delivery set.....	3
Unit designation key.....	4
Basic technical data.....	4
Basic dimensions.....	5
Safety requirements.....	6
Structure and operating diagram.....	6
Mounting and setting-up.....	7
Condensate drainage.....	8
Unit connection to power mains.....	9
Unit operation and control logic.....	10
Servicing and maintenance.....	11
Troubleshooting.....	12
Storage and transportation rules.....	12
Manufacturer's warranty.....	13
Acceptance certificate.....	14
Connection certificate.....	14
Warranty card.....	14



INTRODUCTION

This user's manual combines technical description, operation and service manual, technical data sheet and installation guidelines for the air handling unit with heat utilization VENTS VUT 100 P mini / air handling unit with energy utilization VENTS VUE 100 P mini, hereinafter unit.

APPLICATION

The unit described in this user's manual is the air handling unit with heat utilization (VENTS VUT 100 P mini) or energy utilization (VENTS VUE 100 P mini) and is one the energy saving components used in the buildings and premises. The unit is a complete unit and is not designed for independent operation. The unit is designed to provide permanent controlled air exchange in houses, offices, hotels, cafés, meeting halls and other mechanically ventilated premises as well as utilization of extract air heat energy to warm up supply purified air.

The unit is designed for ceiling mounting.

The unit is rated for continuous operation always connected to power mains.

Operating medium must not contain any flammable or explosive mixtures, evaporation of chemicals, coarse dust, soot and oil particles, sticky substances or fibrous materials or any other harmful substances.



The unit is not designed to be used by children, physically or mentally disabled persons, persons with sensory disorder, persons with no appropriate life experience and/or expertise unless they are properly instructed about the device use or supervised by the person in charge for their safety.

The unit can be operated by qualified experts after careful instruction about its use and operation.

The unit shall be mounted in places inaccessible for children.

DELIVERY SET

- VENTS VUT (VUE) 100 P mini unit - 1 pce.;
- User's operation manual - 1 pce.;
- Packing box - 1 pce.;
- Speed switch P3-1-300. - 1 pce.

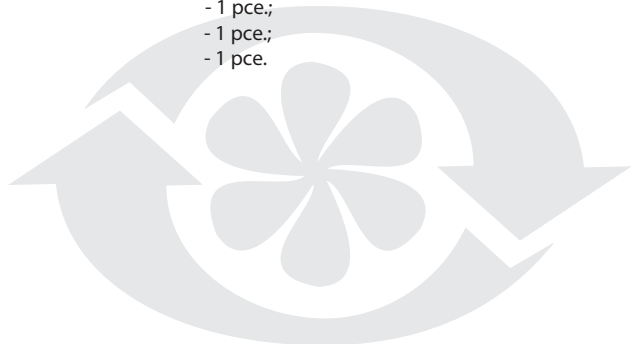

UNIT DESIGNATION KEY

VUT 100 P mini

Casing type

Compact casing.

Modification type**P** – suspended.**Air capacity [m³/h]****Unit type**

VUT – ventilation with heat utilization.

VUT – ventilation with energy utilization.

BASIC TECHNICAL DATA

The unit is designed for indoor application with the ambient temperature ranging from +1°C (34 °F) up to +40°C (104 °F) and relative humidity up to 80%.

Ingress Protection (IP) rating from solid objects and liquids:

- IP 44 for the unit motors (protection from objects equal to or larger than 1.0 mm and splashing water);
- IP 22 for the assembled unit connected to the air ducts (protection from objects equal to or larger than 12.5 mm and water tilted at +/- 15°).

The unit series designation key, the basic overall and connecting dimensions, external view, technical data are shown in fig. 1 and in tables 1 and 2.

The unit design is regularly improved, so some models can slightly differ from those ones described in this manual.

Table 1

	VUT 100 P mini	VUE 100 P mini
Weight [kg]	13	10
Heat exchanger type	Aluminium	Paper

Table 2

Model		VUT(VUE) 100 P mini		
Speed		min.	med.	max.
Voltage, 50 Hz [V]		1~230		
Power [W]		30	38	56
Current [A]		0,18	0,23	0,34
Air capacity [m ³ /h]		57	78	106
Rotation speed [min ⁻¹]		1300	1950	2500
Noise level at 3 m [dBa]		24	32	41
Maximum operating temperature [°C]		-25 up to +50		
Casing material		Aluzink		
Insulation material		Penophole		
Heat insulation layer [mm]		15		
Filter	extract	G4		
	supply	G4		
Connecting air duct dia. [mm]		4 x 125		
Heat utilization efficiency [%]		68		
Moisture utilization efficiency [%]		65		
Heat exchanger type		cross-flow		

BASIC DIMENSIONS

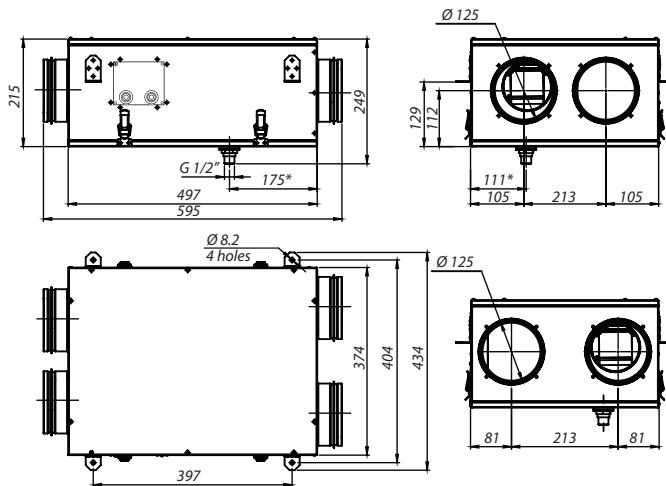

* - for VUT 100 P mini only

Fig. 1

SAFETY REQUIREMENTS

While operating and mounting the unit consider the requirements of the present operation manual as well as general requirements of all applicable local and national building and electrical codes and standards.

Ground the unit before operating!

Before connecting the unit to power mains make sure that the unit is free of any visible damages or any other foreign objects inside the casing that can damage the impeller blades.

Connection of the unit to power mains by duly qualified electricians only!



WARNING!

Mounting, servicing, connection and repair works are allowed after the unit is disconnected from power mains.



DO NOT!

- Do not operate the unit beyond the specified temperature range or in an aggressive and explosive medium.
- Do not connect clothes dryers or similar equipment to the ventilation system.
- Do not operate the unit in the air and dust mixture environment.

STRUCTURE AND OPERATING LOGIC

The unit design and operating logic of the unit is shown fig. 2.

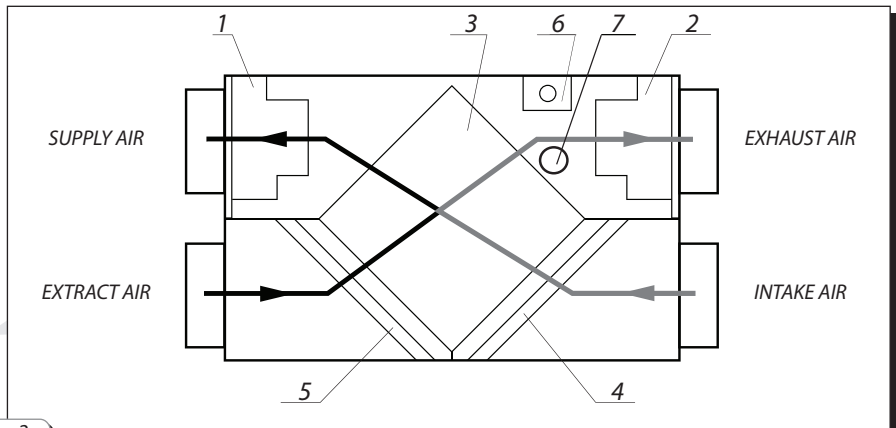
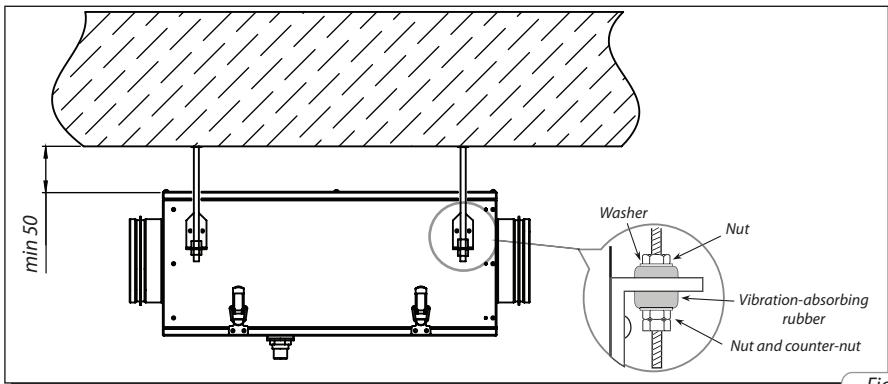
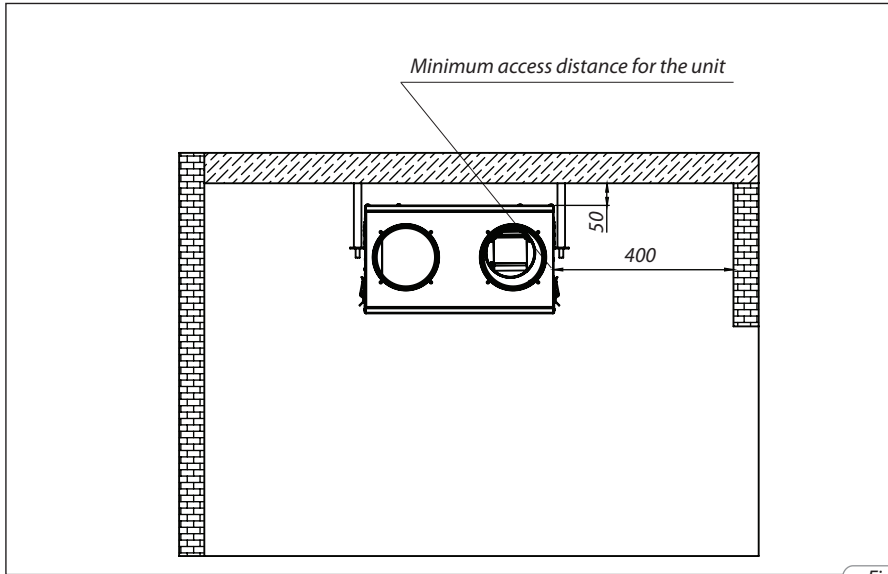

Fig. 2

1. Supply fan
2. Extract fan
3. Plate cross-flow heat exchanger made of aluminium for the model VENTS VUT 100 P mini or paper for the model VENTS VUE 100 P mini.
4. G4 Supply filter
5. G4 Extract filter
6. Thermostatic switch
7. Condensate drain pipe (for the unit VUT 100 P mini only).

MOUNTING AND SETTING-UP

While mounting the unit provide enough space for its servicing and maintenance. Suspend the unit to ceiling by means of the threaded rod fixed inside the threaded dowel, fig. 3.



To gain the best performance of the unit while mounting provide a straight 1 m duct section in front and behind the unit . If the unit is installed at the air duct inlet or outlet it shall be equipped with a grille with the mesh width up to 12.5 mm or any other protecting device to prevent free access to the unit fans.

CONDENSATE DRAINAGE

The unit is equipped with a drain pipe for condensate drainage (only for the unit VENTS VUT 100 P mini). The connection of the unit to drain system is shown in fig. 5.

Connect the condensate drain pipe (1), U-traps (3) and the drainage system with metal, plastic or rubber pipes .

The pipes should be sloped down by min. 3 degrees.

Before starting operation of the unit fill the system with water and check that U-trap is always filled with water. Make sure that the water drainage is correct. Wrong connection to drainage system may result in unwanted water ingress to the room.

The unit with a condensate drainage system is designed for operation at the ambient temperature above 0°C. If the unit is operated in the environment below 0°C it must be thermal-insulated and equipped with heating.

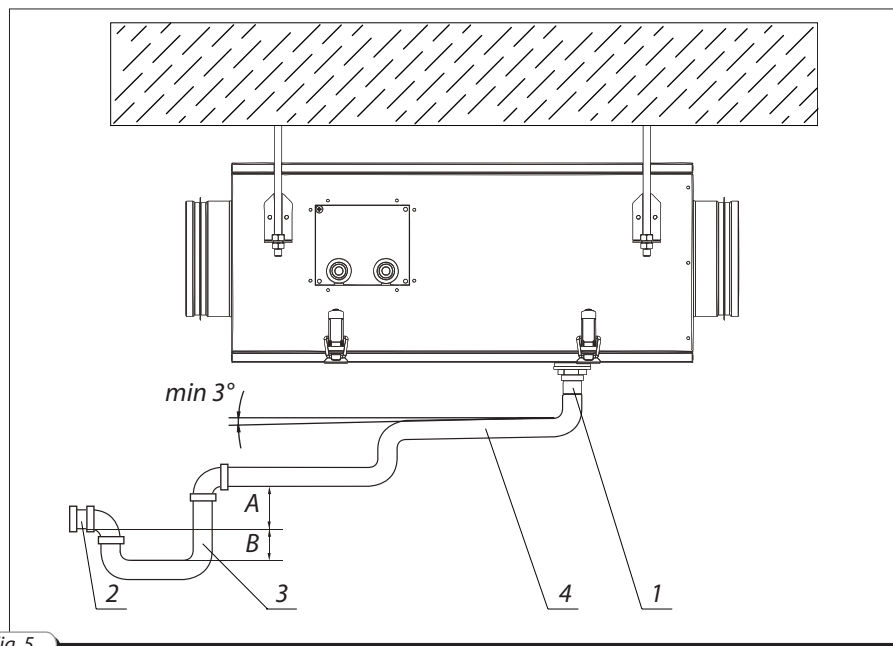

Fig. 5

Check the correct installation of the U-trap considering low pressure in the system produced by the supply fan (fig.5). In this case the maximum developed pressure is 115 Pa and dimension A is about 100 mm and dimension B is about 80 mm.

UNIT CONNECTION TO POWER MAINS



Cut power supply off before any operations with the unit. The unit shall be connected to power mains by duly qualified electricians. The rated values of the electrical parameters are shown on the rating plate. Any modifications of the internal connections are not allowed and will void the warranty.

The unit is rated for connection to single-phase ac 230 V / 50 Hz power mains.

For the unit connection use insulated, durable and heat-resistant wires, cables not less than 0.75 mm². The unit is connected to power mains through the terminal block in compliance with the wiring diagram and terminal designation on the fig. 6. The wiring diagram is also shown inside the terminal box.

Route the wires into the terminal box through an airtight screwed cable gland located at the side wall of the unit to preserve the electric rating class.

Connect the unit to power mains through the external magnetic circuit breaker integrated into the fixed wiring system with min. overload protection 1A.

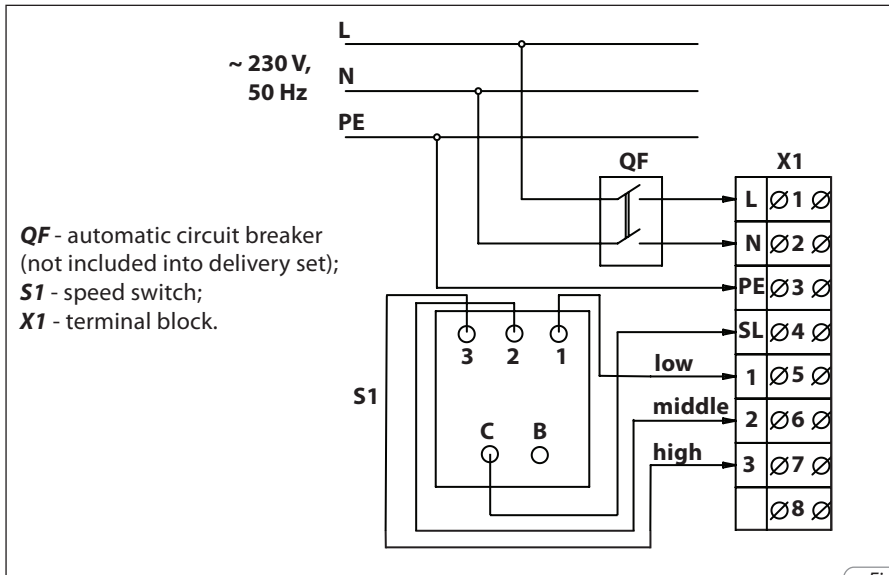

Fig. 6

UNIT OPERATING AND CONTROL LOGIC

The operating logic of the unit is as follows.

Sensible heat energy contained in the extract air flow is transferred in the VENTS VUT 100 P mini unit heat exchanger to the cold intake air flow from outside to warm it up before supplying it to the room.

Both sensible and latent moisture energy contained in the extract air are transferred in the VENTS VUE 100 P mini unit heat exchanger to the cold intake air flow from outside to warm it up before supplying to the room .

The paper heat exchanger of the VENTS VUE 100 P mini unit operates as a moisture balancer in case of too low outdoor humidity or as a air dryer in case of high outdoor air humidity. Due to high hygroscopic features of the heat exchanger materials the unit does not need condensate drainage.

Due to energy and heat utilization by the heat exchanger minimizes thermal energy losses and saves heating costs during cold season.

Air flow in the unit is regulated by the two-speed switch P3-1-300, further the switch. View of the switch as shown in fig. 7.

The thermostatic switch 6 (fig. 2) in the unit casing provides frost protection of the heat exchanger during cold season. The thermostatic switch switches the supply fan off if the heat exchanger needs to be heated with the extract air heat energy.

The thermostatic switch is regulated manually by turning the control knob to set the required thermostatic switch setpoint. The threshold switching value is set individually depending on the operating conditions of the unit. The recommended thermostat setpoint is +3°C (factory setting). Rotate the switch control knob to set the setpoint threshold.

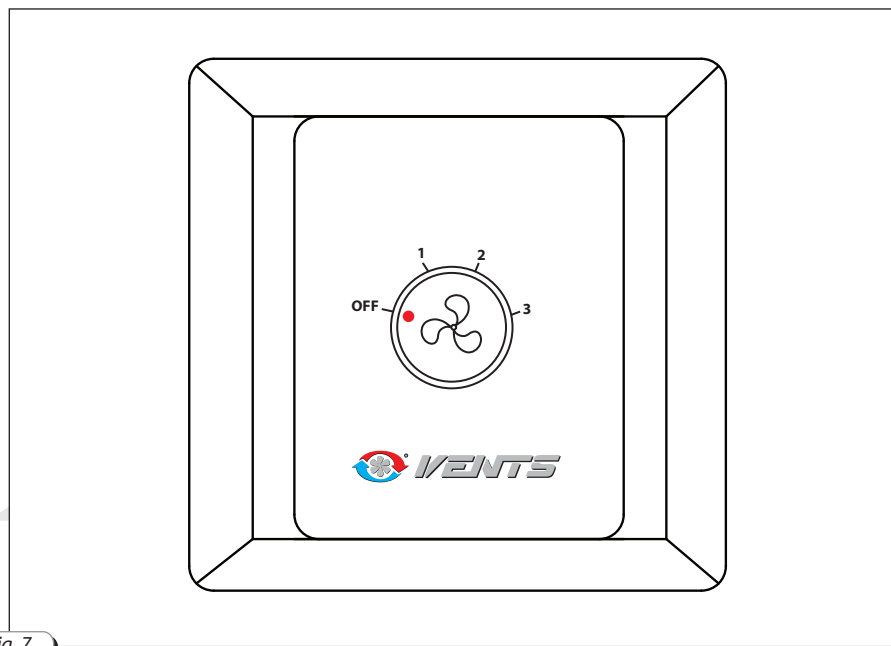

Fig. 7

SERVICING AND MAINTENANCE

Servicing of the unit is required 3-4 times per year. Besides general cleaning, the following operations are required:

1. Filter maintenance (3-4 times per year).

Dirty filters increase air resistance in the system and reduce air flow to the premises. Clean the filters as often as required but at least 3-4 times per year.

Clean the filter with a vacuum cleaner or flush it with water. Contact your local supplier for new filters.

2. Heat exchanger (once per year).

Some dust can get accumulated on the heat exchanger block even if you replace the filters regularly following the above procedure. To maintain high energy / heat exchange efficiency pull out and clean the heat exchanger. Clean the paper heat exchanger of the VENTS VUE 100 P mini unit with a vacuum cleaner. Cleaning with water, abrasive detergents, solVENTS or sharp objects is not allowed. Clean the aluminium heat exchanger of the VENTS VUT 100 P mini with mild detergent solution or vacuum cleaner.

3. Fan inspection (once per year).

Even if you maintain the filters and the heat exchanger regularly in accordance with the above procedures, some dust and grease can get accumulated inside the fans and reduce the fan performance. Clean the fans with a soft brush or a dry cloth. Do not use water and abrasive detergent, sharp objects or solVENTS for cleaning to prevent the impeller damage.

4. Condensate drainage system (for the unit VENTS VUT 100 P mini only) (once per year).

The draining pipe can get clogged with the extracted particles. Clean the drain pipe is required. Make sure that the drain pipeline has sufficient slope and check that the U-trap is filled with water.

5. Supply air flow inspection (twice per year).

Leaves and other objects can clog the intake grille and decrease air flow. Check the intake grille twice per year and clean it as required.

6. Air ductwork inspection (once in 5 years).

Even if you clean and replace the filters regularly a certain amount of dust is accumulated inside the air ducts. That reduces the ventilation system performance. Clean or replace the air ducts periodically.



TROUBLESHOOTING

Possible failures and troubleshooting

Table 3

Problem	Possible reasons	Solving
The fan(s) do(es) not start running.	Power supply is off.	Make sure power supply is connected, otherwise troubleshoot the connection error.
Cold supply air.	Extract filter is clogged.	Clean or replace the extract filter.
	The heat exchanger is frosted.	Check the heat exchanger for frosting. Shut the unit off if required and wait till ice melts. Check the thermostat switch settings to prevent frosting.
Low air capacity.	Low set speed of the fan.	Check the speed controller knob position.
	The filters, fans or the heat exchanger is soiled.	Clean or replace the filters; clean the fans and the heat exchanger.
	The ventilation system is clogged or damaged.	Check the diffusers and louvre gravity shutters opening, check the exhaust hood and intake grille and clean those if required; make sure that the air ducts are not clogged or damaged.
Noise, vibration.	The impeller(s) is (are) clogged.	Clean the fan impeller(s).
	Fan screw tightening is loose.	Check the screw tightening.
Water leakage (only for the Vents VUT 100 P mini unit).	The drain pipe is clogged, damaged or wrong arranged.	Clean the drain pipe. Check the drain pipe slope, U-trap and the correct temperature conditions.

STORAGE AND TRANSPORTATION RULES

Store the unit in the manufacturer's original packing box in a ventilation premise with the temperature range from +10°C up to + 40°C and relative humidity less than 80% (at 20°C).

Use respective hoist machinery for handling operations to prevent possible damages of the unit. Follow all the transportation requirements suitable for the particular cargo type.

Use any vehicle types to transport the goods provided that they are protected against mechanical and weather damage.



MANUFACTURER'S WARRANTY

Manufacturer hereby guarantees normal performance of the unit within 2 years since the date of its sale in accordance to the rules of transportation, storage, assembling and operation. In case of no confirmation of sales date the warranty period is calculated from the production date.

In case of any failures in operation of the unit during the warranty period the manufacturer accepts any claims from the Customer if the technical certificate with the description of the malfunction is provided.

Any unauthorized modifications of the electric connection are not allowed and will void the free warranty service.

Contact the manufacturer or your local seller for both warranty and post-warranty services. For warranty service submit this user's manual with the Seller's stamp, filled connection certificate and warranty card. Warranty and post-warranty repairs are performed at the manufacturing facility.



**WARRANTY CLAIM IS VALID ONLY WITH THIS MANUAL AND FILLED
CONNECTION CERTIFICATE.**



ACCEPTANCE CERTIFICATE

Acceptance certificate
The air handling unit with heat utilization VENTS VUT(VUE) 100 P mini
 is recognized compliant with the technical parameters and serviceable.

Stamp of the acceptance inspector _____ Date of production _____

Sold by

Name of the vendor, stamp of the shop _____

Sale date _____

CONNECTION CERTIFICATE

This is to certify that the air handling unit VENTS VUT(VUE) 100 P mini has been connected to power mains pursuant to the requirements stated in this user's operation manual by the electrical engineer:

Company name: _____

Electrical engineer name: _____

Date _____ Signature _____

WARRANTY CARD

