

**GB**

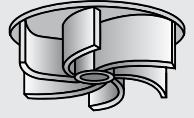

PERFORMANCE CURVES  
CURVE DI PRESTAZIONE

ХАРАКТЕРИСТИЧЕСКИЕ КРИВЫЕ  
COURBE CARACTÉRISTIQUE

CURVA CARACTERÍSTICA  
CURVA CARACTERÍSTICA

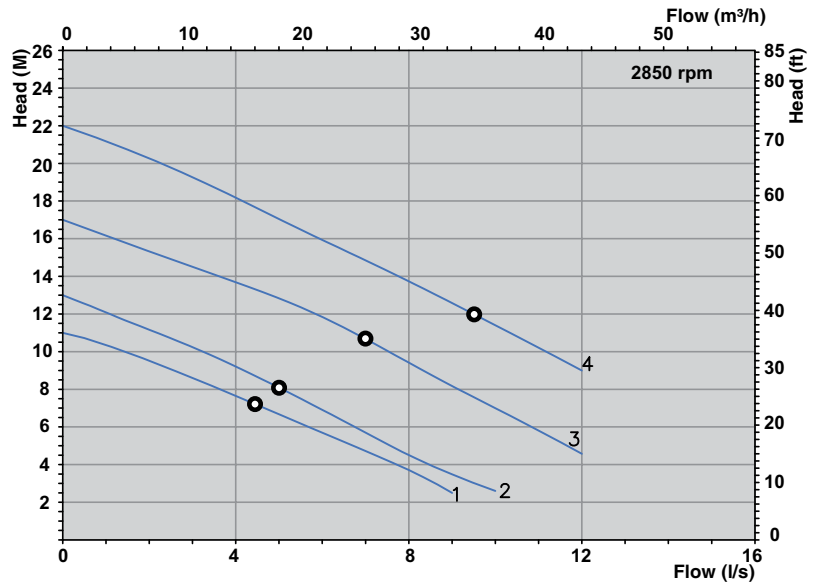

GENERAL FEATURES - CARATTERISTICHE GENERALI - ОСНОВНЫЕ ХАРАКТЕРИСТИКИ CARACTERÍSTICAS GERALES - CARACTERÍSTICAS GENERALES - CARACTERÍSTICA GERAIS										PERFORMANCES - PRESTAZIONI - РАБОЧИЕ ПАРАМЕТРЫ - PERFORMANCES - RENDIMENTO - EXECUÇÃO															
Nr	Modello - Type	P1 kW	P2 kW	Volt	µF	Amp	Giri rpm	DN	Ø mm	l/sec	0	1	2	3	4	5	6	7	8	9	10	11	12		
1	GB - CV08 - EM-AR	1	0.8	230	22	4.6	2850	2"1/2	65	m	11	10.4	9.5	8.5	7.6	6.6	5.6	4.6	3.7	2.5					
1	GB - CV08 - ET - R	1	0.8	400		2.1	2850	2"1/2	65		11	10.4	9.5	8.5	7.6	6.6	5.6	4.6	3.7	2.5					
2	GB - CV12 - EM-A	1.6	1.2	230	30	7.1	2850	2"1/2	65		13	12.1	11.2	10.3	9.3	8	6.9	5.6	4.5	3.5	2.5				
2	GB - CV12 - ET	1.6	1.2	400		3.1	2850	2"1/2	65		13	12.1	11.2	10.3	9.3	8	6.9	5.6	4.5	3.5	2.5				
3	GB - CV18 - ET	2.3	1.85	400		4	2850	2"1/2	65	17	16.2	15.4	14.5	13.6	12.9	11.8	10.6	9.4	8.1	6.9	5.7	4.6			
4	GB - CV26 - ET	3.3	2.6	400		5.9	2850	2"1/2	65	22	21.1	20.4	19.2	18.2	17	15.9	14.9	13.7	12.5	11.4	10.2	9			

INSTALLATION SIZES - DIMENSIONI DI INSTALLAZIONE - УСТАНОВОЧНЫЕ РАЗМЕРЫ - DIMENSIONS D'INSTALLATION - DIMENSIONES DE INSTALACIÓN - DIMENSÕES DE INSTALAÇÃO												
Nr	Modello - Type	A max	A3 max	E	F3	H	DN2	DN4	P3	P4	V	KG
1	GB - CV08 - EM-AR	435	385	70	175	306	2"1/2	2"1/2	282	478	50*	23
1	GB - CV08 - ET - R	435	385	70	175	306	2"1/2	2"1/2	282	478	50*	23
2	GB - CV12 - EM-A	455	405	70	175	306	2"1/2	2"1/2	302	498	50*	24,5
2	GB - CV12 - ET	455	405	70	175	306	2"1/2	2"1/2	302	498	50*	24,5
3	GB - CV18 - ET	485	455	70	175	306	2"1/2	2"1/2	303	428	50*	31,5
4	GB - CV26 - ET	505	455	70	175	306	2"1/2	2"1/2	397	548	50*	38

DIMENSION DRAWINGS  
DIMENSIONI D'INGOMBRO  
ГАБАРИТНЫЕ ЧЕРТЕЖИ  
DIMENSIONS D'ENCOMBREMENT  
DIMENSIONES TOTALES  
DIMENSÕES GLOBAIS

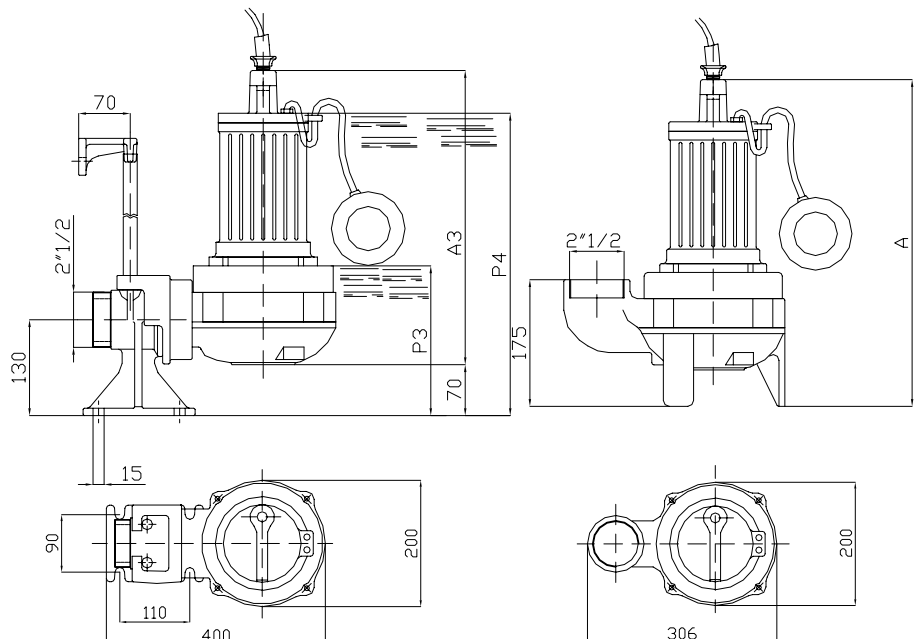

\* In view of continuous developments, the information / descriptions / specifications / illustrations are subject to change without notice.